

**Modular Cooking Range Line
 thermaline 90 - 4-Burner Gas Top on
 Static Gas Oven, 1 Side with Backsplash,
 H=700 (Town Gas)**

ITEM # _____

MODEL # _____

NAME # _____

SIS # _____

AIA # _____

593349 (MCQIEBJCVO)

4-Burner gas Top on gas static Oven, one-side operated with backsplash, town gas

Short Form Specification

Item No. _____

Unit constructed according to DIN 18860_2 with 20 mm drop nose top and 70 mm recessed plinth. Internal frame for heavy duty sturdiness in stainless steel. 2 mm top in 1.4301 (AISI 304). Flat surface construction, easily cleanable. THERMODUL connection system enables seamless worktop when units are connected and avoids soil penetrating. 4 gas burners with optimized combustion, flame failure device, thermocouple safety hand valve and protected pilot flame. Triple ring "flower" flame burners with anti-clogging design. Manual gas valves allow precise flame intensity control. Large pan support in cast iron with long center fins for various pan sizes. Deep flat spillage tray with rounded corners and drain hole. Metal knobs and oven handles with embedded hygienic silicon "soft" grip enable easier handling and cleaning.

Gas static oven chamber with 40 mm thick oven door and ribbed enamelled steel base plate. Oven chamber with 2 levels of runners for 2/1 GN shelves to enable simultaneous and faster cooking. Heavy duty thermostat with temperature range up to 300°C, electronic sensor for precise temperature control and manual humidity control in the cooking chamber. Upper heating element can also be used for grilling, with or without ventilating mode. IPX5 water resistant certification.

Configuration: Freestanding, One-side operated with backsplash.

Main Features

- Flame failure device on each burner protects against gas leakage when accidental extinguishing of the flame occurs.
- Large sized pan support in cast iron with long center fins to allow the use of the largest down to the smallest pans.
- Manual gas valves allow precise control of the flame intensity between high and low positions.
- Manual oven shut-off valve.
- Pans can easily be moved from one area to another without lifting.
- 40 mm thick oven door for heat insulation.
- All major components may be easily accessed from the front.
- THERMODUL connection system creates a seamless work top when units are connected to each other thus avoiding soil penetrating vital components and facilitating the removal of units in case of replacement or service.
- Metal knobs with embedded hygienic "soft-touch" grip for easier handling and cleaning. The special design of the controls prevents infiltration of liquids or soil into vital components.
- Oven chamber to have 2 levels of runners to accommodate 2/1 GN trays and ribbed enamelled steel base plate.
- The upper heating element of the oven can also be used for grilling.
- Manual control of humidity in cooking chamber.
- Electronic sensor for precise temperature control.
- Burners with optimized combustion. Triple ring flower flame burners with anti-clogging design.
- 100% safety pilot and thermocouple.
- Oven temperature up to 300 °C
- Large visible digital display manufactured in tempered glass to resist heat and chemicals, showing temperatures or power settings. The display also shows on/off status of the appliance and on/off status of the heating elements.
- Patented Flower Flame burners that adjust to the size and form of the cookware (Patent EP2708813B1 and related family).

Construction

- Each burner equipped with thermocouple safety hand valve and protected pilot flame.
- 2 mm top in 1.4301 (AISI 304).
- Unit constructed according to DIN 18860_2 with 20 mm drop nose top and 70 mm recessed plinth.
- Flat surface construction with minimal hidden areas to easily clean all surfaces
- IPx4 water protection.
- Internal frame for heavy duty sturdiness in stainless steel.

APPROVAL: _____

Included Accessories

- 1 of Grid, chromium plated, for ovens 2/1 GN PNC 910652

Optional Accessories

- Baking sheet 2/1 GN for ovens PNC 910651
- Bottom steel plate 2/1 GN for fire clay plate 800&900 with baking oven PNC 910655
- Fire clay plate 2/1 GN for ovens PNC 910656
- Connecting rail kit for appliances with backsplash, 900mm PNC 912499
- Portioning shelf, 1000mm width PNC 912528
- Portioning shelf, 1000mm width PNC 912558
- Folding shelf, 300x900mm PNC 912581
- Folding shelf, 400x900mm PNC 912582
- Fixed side shelf, 200x900mm PNC 912589
- Fixed side shelf, 300x900mm PNC 912590
- Fixed side shelf, 400x900mm PNC 912591
- Stainless steel front kicking strip, 1000mm width PNC 912636
- Stainless steel side kicking strips left and right, against the wall, 900mm width PNC 912660
- Stainless steel side kicking strip left and right, back-to-back, 1810mm width PNC 912663
- Stainless steel plinth, against wall, 1000mm width PNC 912941
- Stainless steel plinth, freestanding, 1000mm width PNC 912960
- Connecting rail kit for appliances with backsplash: modular 90 (on the left) to ProThermetic tilting (on the right), ProThermetic stationary (on the left) to ProThermetic tilting (on the right) PNC 912981
- Connecting rail kit for appliances with backsplash: modular 90 (on the right) to ProThermetic tilting (on the left), ProThermetic stationary (on the right) to ProThermetic tilting (on the left) PNC 912982
- Back panel, 1000x700mm, for units with backsplash PNC 913015
- Stainless steel panel, 900x700mm, against wall, left side PNC 913101
- Stainless steel panel, 900x700mm, against wall, right side PNC 913105
- Endrail kit, flush-fitting, with backsplash, left PNC 913117
- Endrail kit, flush-fitting, with backsplash, right PNC 913118
- Endrail kit (12.5mm) for thermaline 90 units with backsplash, left PNC 913208
- Endrail kit (12.5mm) for thermaline 90 units with backsplash, right PNC 913209
- U-clamping rail for back-to-back installations with backsplash (to be ordered as S-code) PNC 913226
- Insert profile d=900 PNC 913232
- Side reinforced panel only in combination with side shelf, for against the wall installations, left PNC 913267
- Side reinforced panel only in combination with side shelf, for against the wall installations, right PNC 913269

- Stainless steel dividing panel, 900x700mm, (it should only be used between Electrolux Professional thermaline Modular 90 and thermaline C90) PNC 913672
- Solid top plate for 7kW and 10kW open burner PNC 913674
- Stainless steel side panel, 900x700mm, flush-fitting (it should only be used against the wall, against a niche and in between Electrolux Professional thermaline and ProThermetic appliances and external appliances - provided that these have at least the same dimensions) PNC 913688

Front

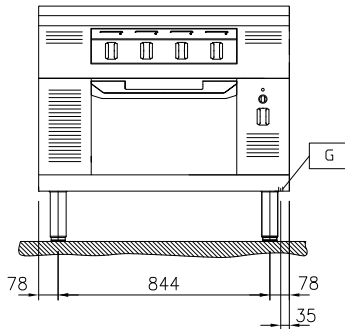

Side

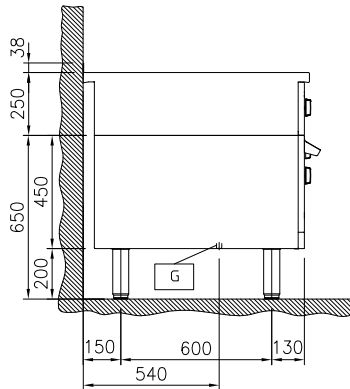

EQ = Equipotential screw
 G = Gas connection

Top

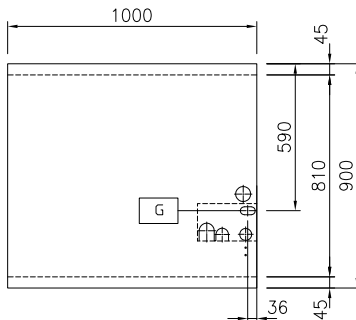
Gas

Gas Power:	41 kW
Gas Type Option:	
Gas Inlet:	1/2"

Key Information:

Oven working Temperature:	80 °C MIN; 300 °C MAX
Oven Cavity Dimensions (width):	683 mm
Oven Cavity Dimensions (height):	255 mm
Oven Cavity Dimensions (depth):	671 mm
External dimensions, Width:	1000 mm
External dimensions, Depth:	900 mm
External dimensions, Height:	700 mm
Net weight:	173 kg
Configuration:	On Oven; One-Side Operated
Front Burners Power:	8.5 - 8.5 kW
Back Burners Power:	8.5 - 8.5 kW
Back Burners Dimension - mm	Ø 70 Ø 70
Front Burners Dimension - mm	Ø 70 Ø 70